

Waste King[®] Gourmet series

by Anaheim Manufacturing

PARTS LIST MODEL SS3300

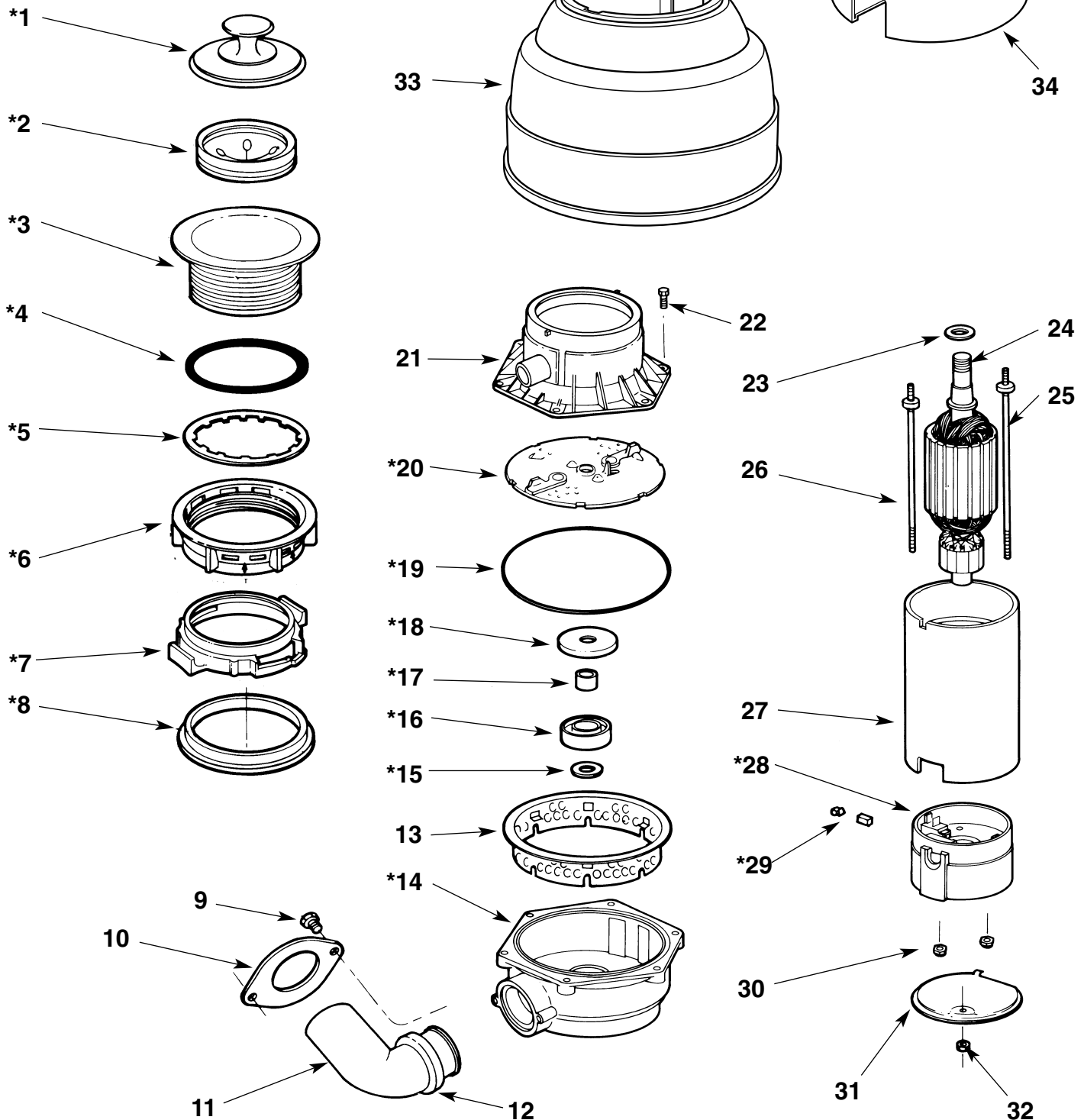

P.O. BOX 4146
ANAHEIM, CA 92803 U.S.A.

* PART OF AN ASSEMBLY, BUT CAN BE PURCHASED SEPARATELY.

ITEM NO.	DESCRIPTION	MODEL SS3300	QTY. PER UNIT
MOUNT ASSEMBLY		.249C019S75	1
*1	STOPPER	.174C067S01	1
*2	SPLASH GUARD	.614C069P01	1
*3	SINKFLANGE & CAP ASSEMBLY	.249C014S35	1
*4	RUBBER GASKET	.269C031P01	1
*5	FIBER GASKET (WAXED)	.269C033P01	1
*6	SUPPORT RING	.614C072P01	1
*7	MOUNT RING	.614C059P02	1
8	CUSHION MOUNT RING	.469C004P02	1
9	OUTLET SCREW	.636C017P03	2
10	OUTLET FLANGE	.249C009P01	1
11	OUTLET ELBOW	.673C015P01	1
12	RUBBER OUTLET GASKET	.269C038P01	1
13	GRIND RING	.614C060P01	1
DRAIN HOUSING ASSEMBLY		.311C082S01	1
*14	DRAIN HOUSING	.311C082P01	1
*15	THRUST WASHER	.789C041P01	1
*16	WATER SEAL	.645C006P01	1
*17	SPACER SEAL	.102C005P01	1
TURNTABLE ASSEMBLY		.258C032S03	1
*18	SLINGER	.789C034P03	1
*19	O-RING	.645C005P01	1
*20	TURNTABLE	.258C032P02	1
21	HOPPER	.311C070P01	1
22	HOPPER SCREW	.636C023P01	6
23	WASHER	.789C035P02	1
24	ARMATURE ASSEMBLY	.626C035P05	1
25	MOTOR STUD	.687C003P02	1
26	MOTOR STUD	.687C003P03	1
27	MOTOR SHELL ASSEMBLY	.681C031S14	1
ENDBELL ASSEMBLY		.311C081S04	1
*28	ENDBELL	.311C081P01	1
*29	MOTOR BRUSH & BRUSH SPRING ASSEMBLY	.027C029S02	1
30	NUT	.479C019P01	2
31	INSPECTION PLATE	.554C032P01	1
32	NUT	.479C021P01	1
33	UPPER SHELL	.806C064P01	1
34	LOWER SHELL	.806C065P01	1
35	SHELL SCREW	.636C024P01	3
†36	SINKFLANGE GASKET-WAXED (THICK)	.269C032P01	1

†NOT SHOWN

*PART OF AN ASSEMBLY, BUT CAN BE PURCHASED SEPARATELY.